

IGEX
count on our value

IGEX
COUNT ON OUR VALUE

NMD 100

Notes and media dispenser

Scaleable solutions for self service automation

The Notes and Media Dispenser NMD 100 is a tower configuration, friction feed multi-denomination mechanism, offering front or rear delivery of banknotes and other value media as well as single note and bundle dispensing. The NMD 100 offers best in class functionality and lowest cost of ownership. No planned maintenance is necessary, other than occasional cleaning which means that your machine is available for longer.



NMD 100

Notes and media dispenser

The NMD 100 is fully modular to allow for flexible configuration from one to eight denominations. The NMD 100 contains three advanced features, unique to De La Rue NMD technology: IDD™, HPF™ and SCL™.

IDD Intelligent Double Detection delivers superb accuracy and consistent detection of doubles even when notes are severely degraded. With IDD, no mechanical adjustments or intervention are required which means that it is ready to use as soon as it is out of the box. IDD enables the single note reject function which powers fast transactions and enables easy reconciliation with few notes to handle from the reject vault.

HPF High Performance Feed provides consistent and durable feeding, reliable handling of notes of all conditions and the ability to process notes without causing damage.

SCL Smart Cassette Logic offers a fully flexible solution with tamperproof cassettes which can be uniquely identified and individually replenished. Short, long, lockable and non-lockable cassette options are available.

Technical specification

- **Media capability**
The NMD 100 will handle the following size and thickness ranges:
Width: 58 to 92mm
Length: 100 to 181mm
Thickness: 0.06 to 0.32mm
- **Maximum note bundle/transaction size**
100 ATM fit banknotes
- **Maximum cassette capacity**
(dependent on thickness and quality)
Short cassette: 240mm or up to 2000 banknotes
Long cassette: 340mm or up to 3000 banknotes
- **Weight (without notes)**
Standard 2-denomination NMD 100 (with cassettes): 22.2kg (48.9lbs)
Additional denomination (without cassette): 3.0kg (6.6 lbs)
Short cassette: 2.2kg (4.9 lbs)
Long cassette: 2.9kg (6.4 lbs)
Reject vault: 2.0kg (4.4 lbs)
- **Throat extensions**
Throat extensions are available in different lengths:
85mm, 130mm, 180mm and 320mm
- **S shutter interface**
The NMD 100 is fitted with an integrated shutter interface. This can be used to control your own shutter or De La Rue can supply a plug-and-play shutter as an option
- **Communication interface**
RS232C connection provided as standard
- **Power supply requirements**
The NMD 100 is fitted with an integrated power supply
The input rating is 120-240V AC 50/60Hz 3A
- **Operating environment**
Temperature: 5 to 50°C, 41 to 122°F
Relative humidity: 10 to 90% non-condensing

Bundle dispensing

The NMD 100 provides bundle dispensing as standard. The bundle presenter brings enhanced security as the mechanism remains in full control of the notes until they are taken by the customer. A separate bundle retract function ensures maximum visibility of uncollected notes or fraudulent transactions.

The NMD 100 is designed in accordance with the recommendations of leading International Standards Organisations such as RoHS, UL and CE to allow for final approval when installed in complete systems.

De La Rue has over 40 years experience in the OEM business. Our mechanisms contain world class dispensing technology. Worldwide service and support is provided through our De La Rue OEM Customer Support Group.

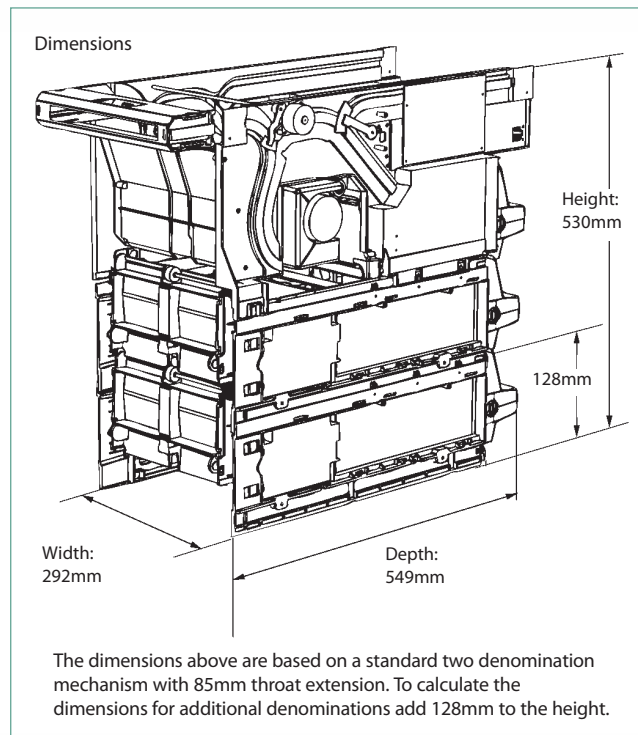

IDD
INTELLIGENT DOUBLE DETECTION™

HPF
HIGH PERFORMANCE FEED™

SCL
SMART CASSETTE LOGIC™

IGEX
Technologies Ltd.

Kimonos 43A, 3095
Limassol, Cyprus

Tel/fax: +357 2693 14 34

www.igex.net

IGEX
COUNT ON OUR VALUE

NMD 50

Notes and Media Dispenser

Scaleable solutions for self service automation

The Notes and Media Dispenser NMD 50 provides a single denomination platform, upgradeable to four denominations. It is a tower configuration, friction feed mechanism offering front delivery of banknotes and other value media. With a small footprint, the NMD 50 has been specifically developed for the expanding retail and non-banking sectors and meets the demands for multi-media dispensing such as tickets, stamps, phone cards and vouchers. No planned maintenance is necessary, other than occasional cleaning which means that your machine is available for longer.



NMD 50

Notes and media dispenser

The NMD 50 contains three advanced features, unique to De La Rue NMD technology: IDD™, HPF™ and SCL™.

IDD Intelligent Double Detection delivers superb accuracy and consistent detection of doubles even when notes are severely degraded. With IDD, no mechanical adjustments or intervention are required which means that it is ready to use as soon as it is out of the box.

HPF High Performance Feed provides consistent and durable feeding, reliable handling of notes of all conditions and the ability to process notes without causing damage.

SCL Smart Cassette Logic offers a fully flexible solution with tamperproof cassettes which can be uniquely identified and individually replenished. Short, long, lockable and non-lockable cassette options are available.

The NMD 50 is available with either a tamper indicating and sealable reject vault or for convenience, a reject tray.

The NMD 50 is designed in accordance with the recommendations of leading International Standards Organisations including RoHS, UL and CE to allow for final approval when installed in complete systems.

De La Rue has over 40 years experience in the OEM business. Our mechanisms contain world class dispensing technology. Worldwide service and support is provided through our De La Rue OEM Customer Support Group.

Technical specification

- **Media capability**
The NMD 50 will handle the following size and thickness ranges:
Width: 58 to 85mm
Length: 100 to 181mm
Thickness: 0.06 to 0.18mm
- **Maximum cassette capacity**
(dependent on thickness and quality)
Short cassette: 240mm or up to 2000 banknotes
Long cassette: 340mm or up to 3000 banknotes
- **Weight (without notes)**
Standard 1-denomination NMD 50 (with cassette): 16.4kg (36.2lbs)
Additional denomination (without cassette): 3.0kg (6.6lbs)
Short cassette: 2.2kg (4.9lbs)
Long cassette: 2.9kg (6.4lbs)
Reject tray: 1.0kg (2.2lbs)
Reject vault: 1.2kg (2.6lbs)
- **Communication interface**
RS232C connection provided as standard
- **Power supply requirements**
The NMD 50 operates from a DC-only supply and requires the following power levels:
+12V ± 10% Max load current 3A
+36V ± 10% Max load current 5A
Power supply units are available from De La Rue as an option
- **Operating environment**
Temperature: 5 to 50°C, 41 to 122°F
Relative humidity: 10 to 90% non-condensing

Dimensions

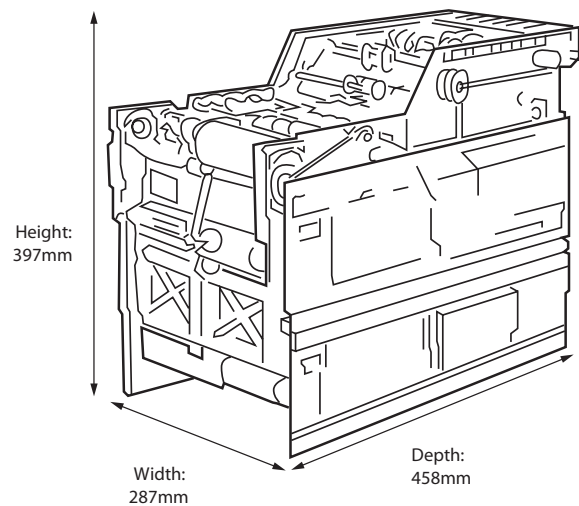

The dimensions above are based on a standard one denomination mechanism. To calculate the dimensions for additional denominations add 128mm to the height.

IDD
INTELLIGENT DOUBLE DETECTION

HPF
HIGH PERFORMANCE FEED

SCL
SMART CASSETTE LOGIC

IGEX
Technologies Ltd.

Kimonos 43A, 3095
Limassol, Cyprus

Tel/fax: +357 2693 14 34

www.igex.net

IGEX
COUNT ON OUR VALUE

IGEX
count on our value

IGEX
COUNT ON OUR VALUE

SDD

Single Denomination Dispenser

The compact and secure mechanism for self-service automation

The Single Denomination Dispenser SDD is an ultra compact, secure, cash dispensing mechanism, available in four variants – front or rear service and standard and short builds. The short variant is one of the smallest secure dispensing mechanisms in the world. The SDD offers a market leading combination of high performance, compact size and low cost of ownership. No planned maintenance is necessary, other than occasional cleaning which means that your machine is available for longer.



SDD

SDD

Single Denomination Dispenser

Central to the SDD is IDD™ Intelligent Double Detection which is unique to De La Rue.

IDD Intelligent Double Detection delivers superb accuracy and consistent detection of doubles even when notes are severely degraded. With IDD, no mechanical adjustments or intervention are required which means that it is ready to use as soon as it is out of the box.

Cassettes

The SDD features secure, tamper indicating feed cassettes with an integral reject note compartment.

Technical specification

- Media capability
The SDD will handle the following size and thickness ranges:
Width: 57mm to 98mm
Length: 110mm to 192mm
Thickness: 0.07 to 0.15mm
- Maximum cassette capacity
(dependent on thickness and quality)
Standard options: a note pile of 260mm or 1650 to 2150 banknotes
Short options: a note pile of 117mm or 700 to 900 banknotes
- Loading frame
The loading frame must be used to open the cassette and also ensures correct loading of documents
- Weight (without notes)
1700 Front service, standard SDD: 8.5kg (18.7lbs)
1701 Front service, short SDD: 7.0kg (15.4lbs)
1702 Rear service, standard SDD: 10.0kg (22.0lbs)
1703 Rear service, short SDD: 8.8kg (19.4lbs)
- Communication interface
RS232C, RS485, TTL serial interface with polling or handshake control, provided as standard
- Power supply requirements
The SDD operates from a DC-only supply and requires the following power levels:
5V DC \pm 0.2V – Max load current 1.5A
36V DC \pm 2V average – Max load current 5A
Power supply units are available from De La Rue as an option
- Operating environment
Temperature:
5 to 50°C, 41 to 122°F
Relative humidity:
10 to 90% non-condensing

The SDD is designed in accordance with the recommendations of leading International Standards Organisations including RoHS, UL and CE to allow for final approval when installed in complete systems.

De La Rue has over 40 years experience in the OEM business. Our mechanisms contain world class dispensing technology. Worldwide service and support is provided through our De La Rue OEM Customer Support Group.

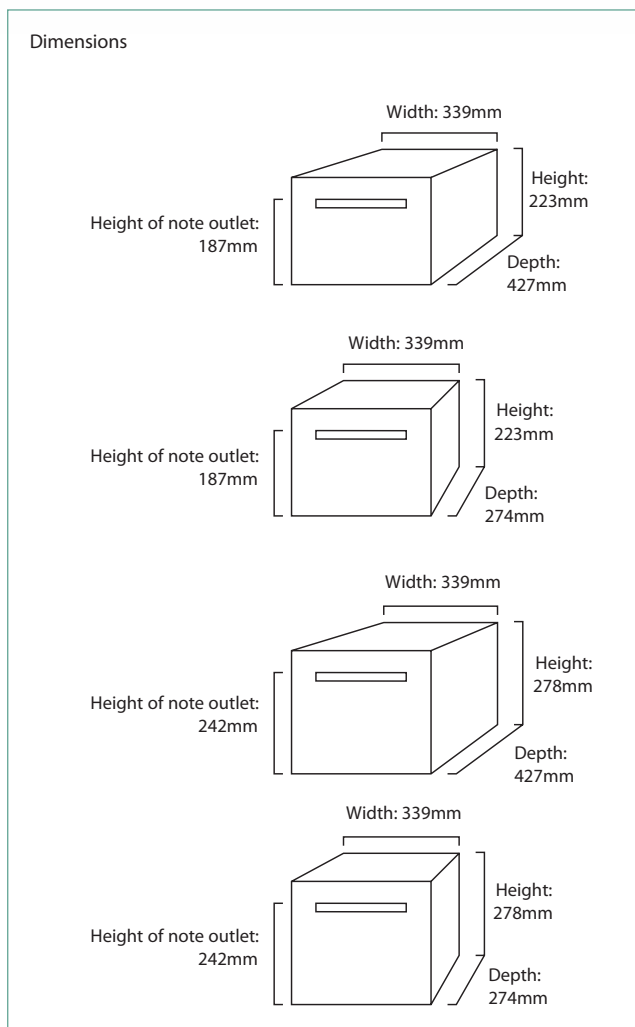

IGEX
Technologies Ltd.

Kimonos 43A, 3095
Limassol, Cyprus

Tel/fax: +357 2693 14 34

www.igex.net



IGEX
count on our value

IGEX
COUNT ON OUR VALUE

MINIMECH™

Single Denomination Dispenser

The ultra compact mechanism for self-service automation

The MINIMECH is an ultra compact single denomination dispensing mechanism, designed to accurately manage and dispense worldwide currencies. Developed for the expanding low-end, low-transaction retail and non-banking sectors, the MINIMECH includes a note tray for up to 1000 notes with an integral reject area, making it ideal for easy merchant cash replenishment of cassettes. No planned maintenance is necessary, other than occasional cleaning which means that your machine is available for longer.

The MINIMECH offers the benefits of feed performance and reliability expected from a De La Rue dispenser, delivering low cost of ownership throughout its product life.

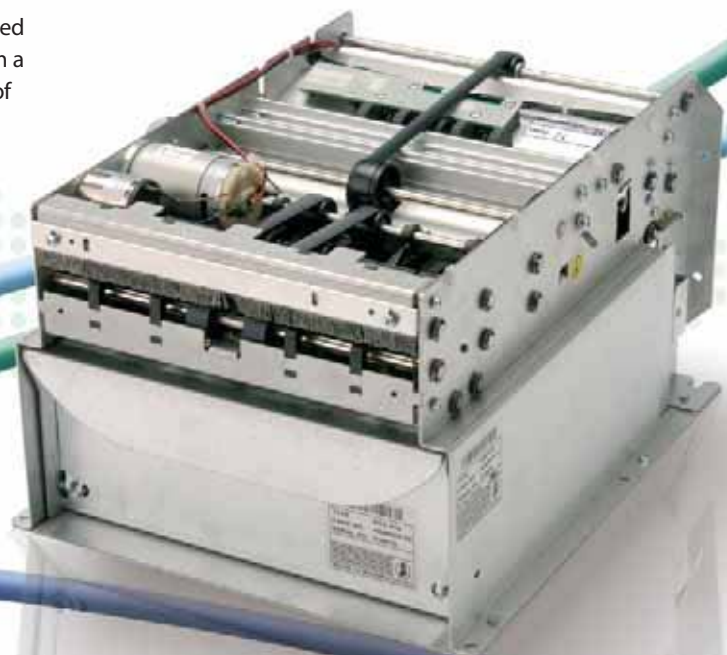

MINIMECH™

MINIMECH™

Single Denomination Dispenser

Central to the MINIMECH is IDD™ Intelligent Double Detection which is unique to De La Rue.

IDD Intelligent Double Detection delivers superb accuracy and consistent detection of doubles even when notes are severely degraded. With IDD, no mechanical adjustments or intervention are required which means that it is ready to use as soon as it is out of the box.

The MINIMECH is:

- Fast
- Easy to use
- Simple to maintain
- Designed to maximise availability
- Communications compatible with the SDD range of dispensers.

The MINIMECH is designed in accordance with the recommendations of leading International Standards Organisations such as RoHS, UL and CE to allow for final approval when installed in complete systems.

De La Rue has over 40 years experience in the OEM business. Our mechanisms contain world class dispensing technology. Worldwide service and support is provided through our De La Rue OEM Customer Support Group.

Technical specification

- Media capability
The MINIMECH will handle the following size and thickness ranges:
Width: 60 to 82mm
Length: 110 to 180mm
Thickness: 0.06 to 0.18mm
- Maximum note tray capacity
(dependent on thickness and quality)
A note pile of 110mm or up to 1000 banknotes
- Weight
Mechanism (without tray and notes): 5.3kg (11.7lbs)
Note tray with inclusive reject compartment (without notes): 1.6kg (3.5lbs)
- Communication interface
MINIMECH runs the same communications protocol as the SDD range of cash dispensers allowing for plug and play compatibility
RS232C connection provided as standard
- Power supply requirements
The mechanism operates from a DC-only supply and requires the following power level
24V ± 10% – Max load current 2.5A
- Operating environment
Temperature:
10 to 50°C, 50 to 122°F
Relative humidity:
10 to 90% non-condensing

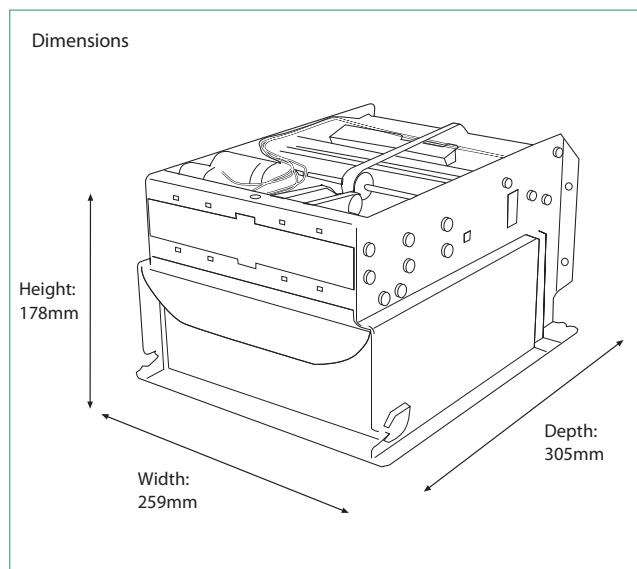

IGEX
Technologies Ltd.

Kimonos 43A, 3095
Limassol, Cyprus

Tel/fax: +357 2693 14 34

www.igex.net



MDDM

Multi-Denomination Dispensing Mechanism

Modular solutions for full function self-service automation

The Multi-Denomination Dispensing Mechanism MDDM is a friction feed mechanism in a horizontal configuration. It is a world leading dispenser for full function ATMs and other self-service applications. The MDDM is a modular mechanism allowing for flexible mechanical integration with a cassette capacity of up to 2000 notes. No planned maintenance is necessary, other than occasional cleaning which means that your machine is available for longer.

The MDDM offers the following key benefits:

- Bundle delivery of notes
- Top delivery system
- Tamperproof cassettes
- One to six denominations



MDDM

Multi-Denomination Dispensing Mechanism

Central to the MDDM is IDD™ Intelligent Double Detection which is unique to De La Rue.

IDD Intelligent Double Detection delivers superb accuracy and consistent detection of doubles even when notes are severely degraded. With IDD, no mechanical adjustments or intervention are required which means that it is ready to use as soon as it is out of the box.

Cassettes

The MDDM cassettes provide outstanding functionality as follows:

- Tamperproof cassettes which interlock both mechanically and electronically, allowing for service access without the need to remove cassettes from your machine
- Flexibility to switch cassette positions within your dispenser or change feed order (cassette position or note size order)
- Ability to allocate a currency and a denomination to a cassette

Technical specification

- Media capability
The MDDM will handle the following size and thickness ranges:
Width: 55 to 97mm
Length: 110 to 181mm
Thickness: 0.06 to 0.18mm
- Maximum note bundle/transaction size
Up to 40 ATM fit banknotes
- Maximum cassette capacity
(dependent on thickness and quality)
230mm or up to 2000 banknotes
- Weight (without notes)
Based on 2 denominations: 50kg (110.2lbs)
- Communication interface
RS232C connection provided as standard
- Power supply requirements
MDDM operates from an AC-only supply and requires the following power levels:
100-240V AC, 50/60 Hz, 3A
- Operating environment
Temperature:
10 to 40°C, 32 to 104°F
Relative humidity:
20 to 80% non-condensing

Cassettes are available in three versions: with an electronic lock, with a key lock or without a lock.

Loading frame

The loading frame is used for convenient and correct loading of banknotes in the feed cassettes. Electronically locked cassettes can only be opened with the loading frame, which provides a high degree of security.

The MDDM is designed in accordance with the recommendations of leading international Standards Organisations such as RoHS, UL and CE to allow for final approval when installed in complete systems.

De La Rue has over 40 years experience in the OEM business. Our mechanisms contain world class dispensing technology. Worldwide service and support is provided through our De La Rue OEM Customer Support Group.

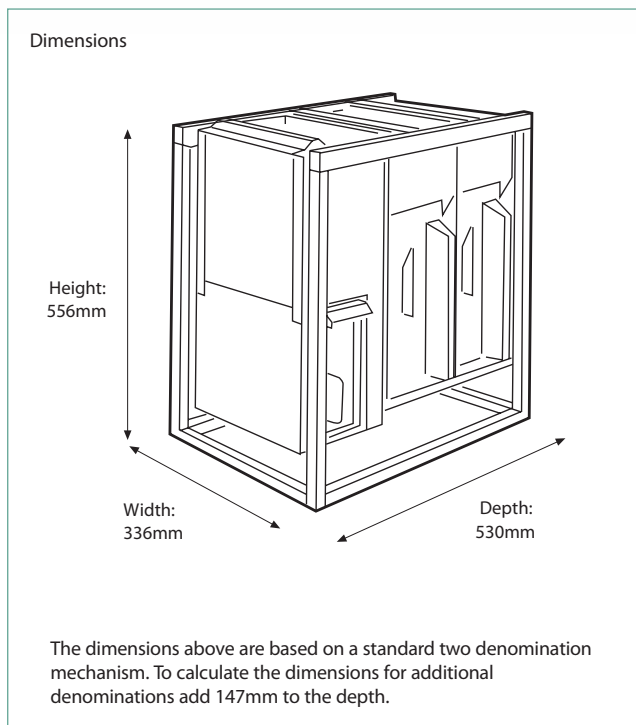

IGEX
Technologies Ltd.



Kimonos 43A, 3095
Limassol, Cyprus

Tel/fax: +357 2693 14 34

www.igex.net

IGEX
count on our value

IGEX
COUNT ON OUR VALUE

INSTACHANGE™ (OEM)

Automatic Coin Dispenser

Intelligent, reliable coin dispensing

The INSTACHANGE (OEM) is a truly revolutionary automatic cash dispenser which represents a major design breakthrough in coin dispensing technology. Its ground-breaking design means an increase in coin capacity of up to 30% compared with competitor dispensers.



INSTACHANGE™
(OEM)

INSTACHANGE™ (OEM)

Automatic Coin Dispenser

Revolutionary universal design

The innovative design of the INSTACHANGE (OEM) keeps moving parts to a minimum resulting in a lower cost of ownership and increased reliability. The patented and unique coin cassette shape provides greater capacity allowing INSTACHANGE (OEM) to run longer requiring less employee support. The universal base supports a variety of coin set cassettes making it easy to maximise the use of your equipment and minimise service support variations.

Intelligent functionality

INSTACHANGE (OEM) automatically dispenses the right amount of change back to your customer. It will always dispense the least amount of coin required, unless this functionality is switched off. If selected, INSTACHANGE (OEM) will intelligently substitute for low channels, further extending the running time of your machine.

Ease of use

The shape of the coin cassette makes it easy to transport and store. The INSTACHANGE (OEM) can be positioned in any direction so that the coin cup is within easy reach of the customer. The coin cup can also be easily removed.

When INSTACHANGE (OEM) requires topping up, coin is easily loaded into the coin cassette while it sits either on the universal base or flat on a table. Balancing is aided through the use of colour coded calibration labels.

Interfaces

Each unit is delivered with standard software drivers (OPOS, JPOS, Linux, JXFS) allowing INSTACHANGE (OEM) to quickly interface with your self service application.

The INSTACHANGE (OEM) is designed to comply with leading International Standards such as RoHS, UL and CE to allow for final approval when installed in complete systems.

De La Rue has over 40 years experience in the OEM business. Our mechanisms contain world class dispensing technology. Worldwide service and support is provided through our De La Rue OEM Customer Support Group.

Technical specification

- Media capability
The INSTACHANGE (OEM) will handle the following currencies:
 - British Sterling
 - Canadian Dollar
 - Euro
 - American DollarPlease contact us for availability of coin set cassettes for other currencies
- Mounting hardware
Installation template and bolt down kit provided as standard
- Additional cassettes
Can be ordered from De La Rue for a quick exchange
- Weight (without coins)
 - Base, cassette (with cup): 2.8kg (6.2lbs)
 - Base, cassette (without cup): 2.7kg (5.9lbs)
 - Cassette only: 0.7kg (1.6lbs)
- Communication interface
RS232 or USB host communication
- Power supply requirements
12V DC, 3.2A
- Operating environment
 - Temperature: 5 to 50°C, 41 to 122°F
 - Relative humidity: 10 to 90% non-condensing

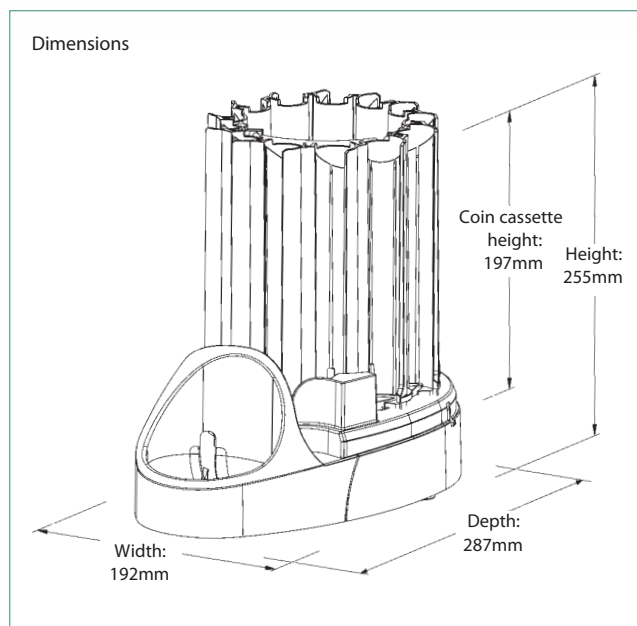

IGEX
Technologies Ltd.

Kimonos 43A, 3095
Limassol, Cyprus

Tel/fax: +357 2693 14 34

www.igex.net

IGEX
COUNT ON OUR VALUE

IGEX
count on our value

IGEX
COUNT ON OUR VALUE

EDM

Envelope Deposit Mechanism

The fast and reliable mechanism for envelope deposit

The EDM is a fast, reliable envelope deposit mechanism which facilitates the deposit of envelopes containing banknotes and/or cheques. The mechanism is easy to integrate and connect to any self-service application.

The EDM offers the following key benefits:

- It saves space
- It increases efficiency
- It facilitates reconciliation
- It provides a deposit capacity of up to 60 envelopes



EDM

Envelope Deposit Mechanism

Dual functionality

The EDM offers dual functionality; it is capable of dispensing envelopes as well as accepting envelopes containing banknotes and/or cheques.

Saving space

With a built-in envelope dispenser, there is no need to accommodate a separate envelope dispensing unit thus saving you space.

Increasing efficiency

Envelopes dispensed from the EDM are in a recognised format. This means that when an envelope is deposited, the EDM can easily identify it, increasing the efficiency of the transaction for your customer.

Facilitating reconciliation

Once deposited, the envelope is transported via a conveyor system to a printer unit where it is presented for printing. With a resolution of 300-dpi the internal

ink-jet printer is capable of printing bar codes as well as up to 80 characters per line. The EDM ensures the envelope is clearly identified which facilitates back office reconciliation.

Deposit capacity

The EDM provides a fixed deposit compartment with a capacity of up to 60 envelopes.

The EDM is designed in accordance with the recommendations of leading International Standards Organisations such as RoHS, UL and CE to allow for final approval when installed in complete systems.

De La Rue has over 40 years experience in the OEM business. Our mechanisms contain world class dispensing technology. Worldwide service and support is provided through our De La Rue OEM Customer Support Group.

Technical specification

- Media capability
The EDM envelope dimensions are as follows:
Width: 110 to 120mm
Length: 190 to 230mm
- Maximum dispensing capacity
Up to 390 envelopes with an average thickness of 0.5mm
- Maximum deposit capacity
Up to 60 envelopes with average thickness of 3mm
- Weight
24kg (52.9lbs)
- Communication interface
PC driven module
RS232 or USB host communication
- Power supply requirements
The EDM operates from a DC-only supply, requiring the following power level: 24V DC \pm 5% – Max load current 3A
- Operating environment
Temperature:
0 to 40°C, 32 to 104°F
Relative humidity:
20 to 80% non-condensing
- Storage
Temperature:
0 to 45°C, 32 to 113°F
Relative humidity:
5 to 95% non-condensing

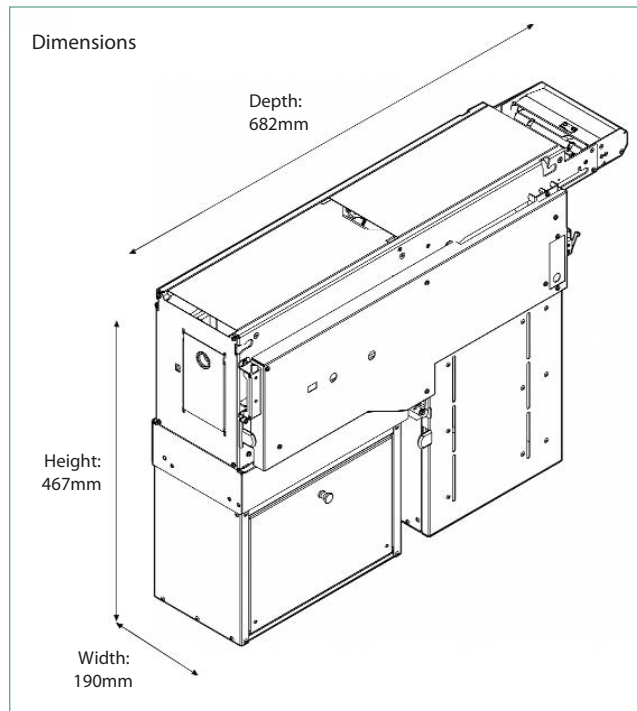

IGEX
Technologies Ltd.

Kimonos 43A, 3095
Limassol, Cyprus

Tel/fax: +357 2693 14 34

www.igex.net

IGEX
COUNT ON OUR VALUE