

IGEX  
count on our value

**IGEX**  
COUNT ON OUR VALUE

## EDM

### Envelope Deposit Mechanism

The fast and reliable mechanism for envelope deposit

The EDM is a fast, reliable envelope deposit mechanism which facilitates the deposit of envelopes containing banknotes and/or cheques. The mechanism is easy to integrate and connect to any self-service application.

The EDM offers the following key benefits:

- It saves space
- It increases efficiency
- It facilitates reconciliation
- It provides a deposit capacity of up to 60 envelopes



# EDM

## Envelope Deposit Mechanism

### Dual functionality

The EDM offers dual functionality; it is capable of dispensing envelopes as well as accepting envelopes containing banknotes and/or cheques.

### Saving space

With a built-in envelope dispenser, there is no need to accommodate a separate envelope dispensing unit thus saving you space.

### Increasing efficiency

Envelopes dispensed from the EDM are in a recognised format. This means that when an envelope is deposited, the EDM can easily identify it, increasing the efficiency of the transaction for your customer.

### Facilitating reconciliation

Once deposited, the envelope is transported via a conveyor system to a printer unit where it is presented for printing. With a resolution of 300-dpi the internal

ink-jet printer is capable of printing bar codes as well as up to 80 characters per line. The EDM ensures the envelope is clearly identified which facilitates back office reconciliation.

### Deposit capacity

The EDM provides a fixed deposit compartment with a capacity of up to 60 envelopes.

The EDM is designed in accordance with the recommendations of leading International Standards Organisations such as RoHS, UL and CE to allow for final approval when installed in complete systems.

De La Rue has over 40 years experience in the OEM business. Our mechanisms contain world class dispensing technology. Worldwide service and support is provided through our De La Rue OEM Customer Support Group.

## Technical specification

- Media capability  
The EDM envelope dimensions are as follows:  
Width: 110 to 120mm  
Length: 190 to 230mm
- Maximum dispensing capacity  
Up to 390 envelopes with an average thickness of 0.5mm
- Maximum deposit capacity  
Up to 60 envelopes with average thickness of 3mm
- Weight  
24kg (52.9lbs)
- Communication interface  
PC driven module  
RS232 or USB host communication
- Power supply requirements  
The EDM operates from a DC-only supply, requiring the following power level: 24V DC  $\pm$  5% – Max load current 3A
- Operating environment  
Temperature:  
0 to 40°C, 32 to 104°F  
Relative humidity:  
20 to 80% non-condensing
- Storage  
Temperature:  
0 to 45°C, 32 to 113°F  
Relative humidity:  
5 to 95% non-condensing

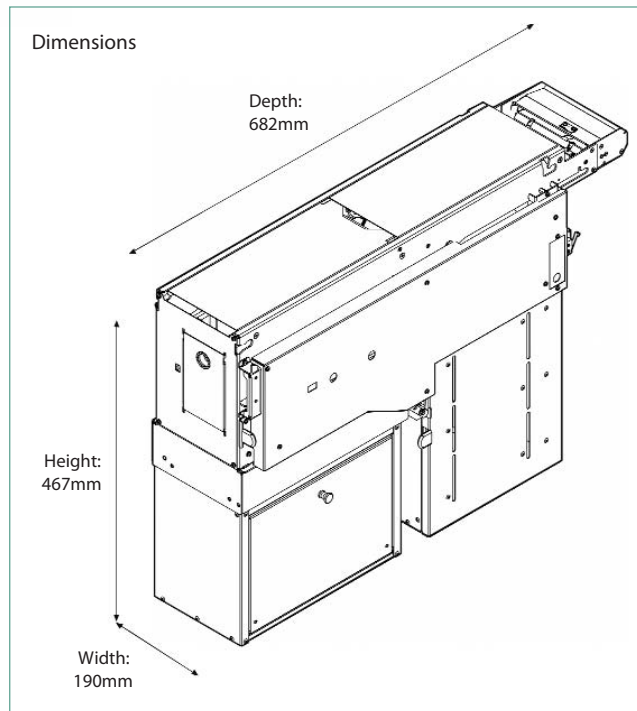

IGEX  
Technologies Ltd.

Kimonos 43A, 3095  
Limassol, Cyprus

Tel/fax: +357 2693 14 34

[www.igex.net](http://www.igex.net)

**IGEX**  
COUNT ON OUR VALUE