

IGEX
count on our value

IGEX
COUNT ON OUR VALUE

NMD 100

Notes and media dispenser

Scaleable solutions for self service automation

The Notes and Media Dispenser NMD 100 is a tower configuration, friction feed multi-denomination mechanism, offering front or rear delivery of banknotes and other value media as well as single note and bundle dispensing. The NMD 100 offers best in class functionality and lowest cost of ownership. No planned maintenance is necessary, other than occasional cleaning which means that your machine is available for longer.



NMD 100

Notes and media dispenser

The NMD 100 is fully modular to allow for flexible configuration from one to eight denominations. The NMD 100 contains three advanced features, unique to De La Rue NMD technology: IDD™, HPF™ and SCL™.

IDD Intelligent Double Detection delivers superb accuracy and consistent detection of doubles even when notes are severely degraded. With IDD, no mechanical adjustments or intervention are required which means that it is ready to use as soon as it is out of the box. IDD enables the single note reject function which powers fast transactions and enables easy reconciliation with few notes to handle from the reject vault.

HPF High Performance Feed provides consistent and durable feeding, reliable handling of notes of all conditions and the ability to process notes without causing damage.

SCL Smart Cassette Logic offers a fully flexible solution with tamperproof cassettes which can be uniquely identified and individually replenished. Short, long, lockable and non-lockable cassette options are available.

Technical specification

- **Media capability**
The NMD 100 will handle the following size and thickness ranges:
Width: 58 to 92mm
Length: 100 to 181mm
Thickness: 0.06 to 0.32mm
- **Maximum note bundle/transaction size**
100 ATM fit banknotes
- **Maximum cassette capacity**
(dependent on thickness and quality)
Short cassette: 240mm or up to 2000 banknotes
Long cassette: 340mm or up to 3000 banknotes
- **Weight (without notes)**
Standard 2-denomination NMD 100 (with cassettes): 22.2kg (48.9lbs)
Additional denomination (without cassette): 3.0kg (6.6 lbs)
Short cassette: 2.2kg (4.9 lbs)
Long cassette: 2.9kg (6.4 lbs)
Reject vault: 2.0kg (4.4 lbs)
- **Throat extensions**
Throat extensions are available in different lengths:
85mm, 130mm, 180mm and 320mm
- **S shutter interface**
The NMD 100 is fitted with an integrated shutter interface. This can be used to control your own shutter or De La Rue can supply a plug-and-play shutter as an option
- **Communication interface**
RS232C connection provided as standard
- **Power supply requirements**
The NMD 100 is fitted with an integrated power supply
The input rating is 120-240V AC 50/60Hz 3A
- **Operating environment**
Temperature: 5 to 50°C, 41 to 122°F
Relative humidity: 10 to 90% non-condensing

Bundle dispensing

The NMD 100 provides bundle dispensing as standard. The bundle presenter brings enhanced security as the mechanism remains in full control of the notes until they are taken by the customer. A separate bundle retract function ensures maximum visibility of uncollected notes or fraudulent transactions.

The NMD 100 is designed in accordance with the recommendations of leading International Standards Organisations such as RoHS, UL and CE to allow for final approval when installed in complete systems.

De La Rue has over 40 years experience in the OEM business. Our mechanisms contain world class dispensing technology. Worldwide service and support is provided through our De La Rue OEM Customer Support Group.

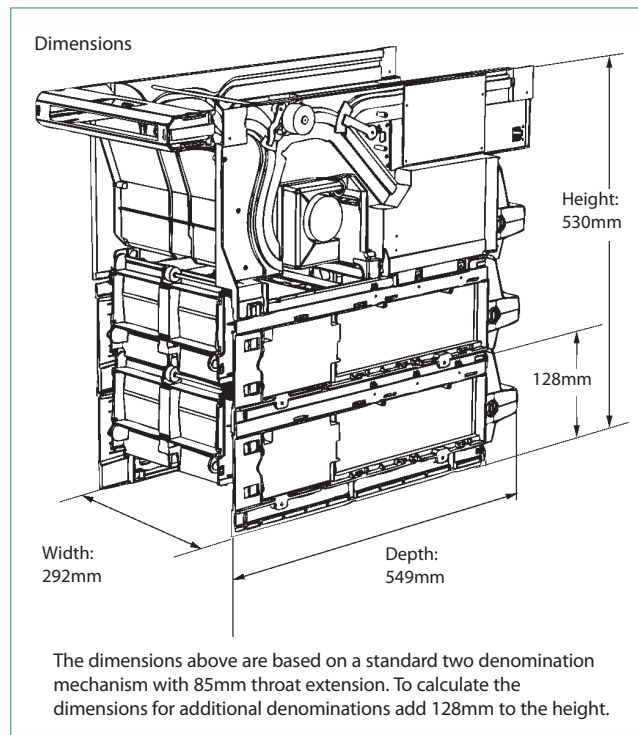

IDD
INTELLIGENT DOUBLE DETECTION™

HPF
HIGH PERFORMANCE FEED™

SCL
SMART CASSETTE LOGIC™

IGEX
Technologies Ltd.

Kimonos 43A, 3095
Limassol, Cyprus

Tel/fax: +357 2693 14 34

www.igex.net

IGEX
COUNT ON OUR VALUE