

MDDM

Multi-Denomination Dispensing Mechanism

Modular solutions for full function self-service automation

The Multi-Denomination Dispensing Mechanism MDDM is a friction feed mechanism in a horizontal configuration. It is a world leading dispenser for full function ATMs and other self-service applications. The MDDM is a modular mechanism allowing for flexible mechanical integration with a cassette capacity of up to 2000 notes. No planned maintenance is necessary, other than occasional cleaning which means that your machine is available for longer.

The MDDM offers the following key benefits:

- Bundle delivery of notes
- Top delivery system
- Tamperproof cassettes
- One to six denominations



MDDM

Multi-Denomination Dispensing Mechanism

Central to the MDDM is IDD™ Intelligent Double Detection which is unique to De La Rue.

IDD Intelligent Double Detection delivers superb accuracy and consistent detection of doubles even when notes are severely degraded. With IDD, no mechanical adjustments or intervention are required which means that it is ready to use as soon as it is out of the box.

Cassettes

The MDDM cassettes provide outstanding functionality as follows:

- Tamperproof cassettes which interlock both mechanically and electronically, allowing for service access without the need to remove cassettes from your machine
- Flexibility to switch cassette positions within your dispenser or change feed order (cassette position or note size order)
- Ability to allocate a currency and a denomination to a cassette

Technical specification

- Media capability
The MDDM will handle the following size and thickness ranges:
Width: 55 to 97mm
Length: 110 to 181mm
Thickness: 0.06 to 0.18mm
- Maximum note bundle/transaction size
Up to 40 ATM fit banknotes
- Maximum cassette capacity
(dependent on thickness and quality)
230mm or up to 2000 banknotes
- Weight (without notes)
Based on 2 denominations: 50kg (110.2lbs)
- Communication interface
RS232C connection provided as standard
- Power supply requirements
MDDM operates from an AC-only supply and requires the following power levels:
100-240V AC, 50/60 Hz, 3A
- Operating environment
Temperature:
10 to 40°C, 32 to 104°F
Relative humidity:
20 to 80% non-condensing

Cassettes are available in three versions: with an electronic lock, with a key lock or without a lock.

Loading frame

The loading frame is used for convenient and correct loading of banknotes in the feed cassettes. Electronically locked cassettes can only be opened with the loading frame, which provides a high degree of security.

The MDDM is designed in accordance with the recommendations of leading international Standards Organisations such as RoHS, UL and CE to allow for final approval when installed in complete systems.

De La Rue has over 40 years experience in the OEM business. Our mechanisms contain world class dispensing technology. Worldwide service and support is provided through our De La Rue OEM Customer Support Group.

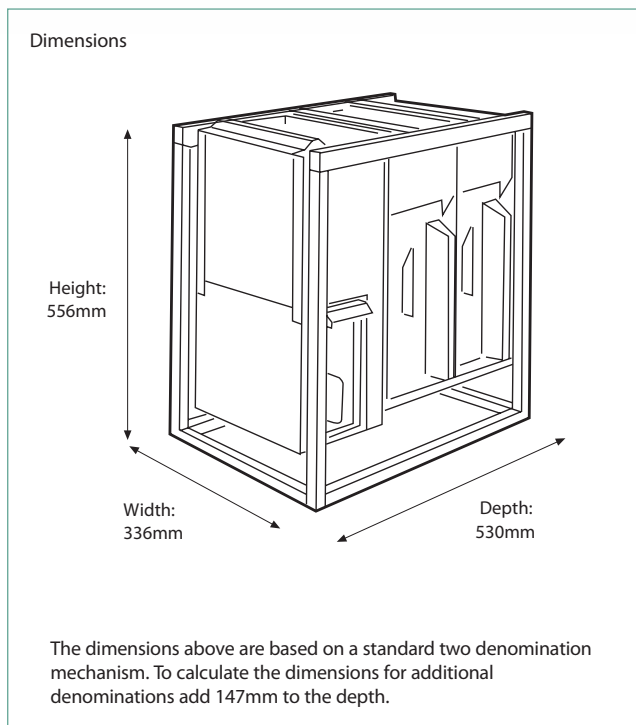

IGEX
Technologies Ltd.



Kimonos 43A, 3095
Limassol, Cyprus

Tel/fax: +357 2693 14 34

www.igex.net